

LMC2014_FIBER_CUH_V4(1)

USBLMC Client Use Handbook

Fiber Laser Control Board

Version recorder

version	Date	Comment
V1.0	2007-1	
V1.1	2007-6	
V1.2	2008-5	
V1.3	2008-5-12	Compatible with both B and D type YLP laser, change the power supply connection method
V1.4	2009-12-12	Change IN0 and IN4
V2	2010-12-2	Interface board and main board embeded together, and laser state signal and external axis signal adopt special input signal. Laser error state output signal. 16 routes of IO signals.
V3	2014-9-11	Hardware and feature

Content

Safety instruction	
Safety During Installation And Operation.....	1
. Common Digital Module	2
1.1 How to identify a LMC FIBER-V4 board.....	2
1.2 main feature.....	3
1.3 Version illustration	3
2 electrical wiring.....	3
2.1 pin definition	3
2.1.1 power supply	3
2.1.2 CON1 : DB15 scanhead control.....	4
2.1.3 CON2 : DB25 Laser Control	5
2.1.4 CON3 : DB9 On-the-fly interface.....	6
2.1.5 CON4 : DB15 power supply and extension axis control.....	7
2.1.6 CON5: 2.1.6 CON5: DB25 digital IO.....	9
2.2 2.2 illustration on jumpers.....	11
2.3 wiring for digital I/O.	12
2.3.1 I/O that can be connect to GND.....	12
2.3.2 input signal In9-In13	13
2.3.3 Out0——Out7	14
2.3.5 Typical Connection of Digital Module	15

Safety During Installation And Operation

Please read these operating instruction completely before you proceed with installing and operating this product. If there are any questions regarding the contents of this manual, please contact BJJCZ.

1. Steps For Safe Operation

- Carefully check your application program before running it. Programming errors can cause a breakdown of the system. In this case neither the laser nor the scan head can be controlled.
- Protect the board from humidity, dust, corrosive vapors and mechanical stress.
- For storage and operation, avoid electromagnetic fields and static electricity. These can damage the electronics on the product. For storage, always use the antistatic bag.
- The allowed operating temperature range is $25^{\circ}\text{C} \pm 10^{\circ}\text{C}$.
- The storage temperature should be between -20°C and $+60^{\circ}\text{C}$.

2. Laser Safety

- This product is intended for controlling a laser scan system. Therefore all relevant laser safety directives must be known and applied before installation and operation. The customer is solely responsible for ensuring the laser safety of the entire system.
- All applicable laser safety directives must be adhered to. Safety regulation may differ from country to country. It is the responsibility of the customer to comply with all local regulations.
- Please observe all laser safety instructions as described in you scan head or scan module manual, and this manual.
- **Always turn on the power of this product and the power supply for the scan head first before turning on the laser. Otherwise there is the danger of uncontrolled deflection of the laser beam.**

We recommend the use of a shutter to prevent uncontrolled emission of laser radiation.

. Common Digital Module

1.1 How to identify a LMC FIBER board.

Place the board like the following picture. Then you will see a label marked MODEL:
LMCFIBER2014-V4 and REV: 20141022

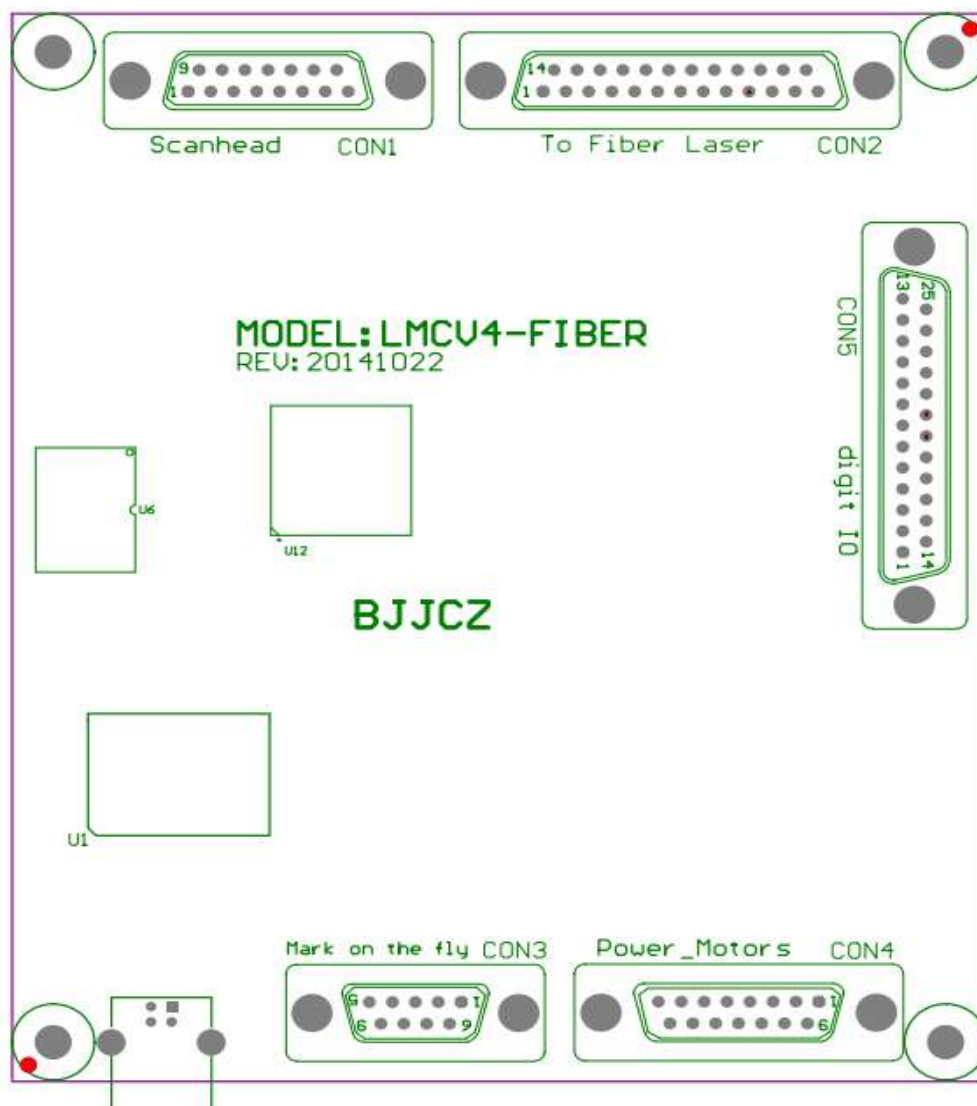

Fig 1-1 LMC20104-V4 Fiber card illustration

In this picture,

CON1: scanhead control socket, DB15

CON2: laser control socket, DB25

CON3: on-the-fly marking interface to encoder, DB9

CON4: power supply and i/o, DB15

CON5: general i/os, DB25

1.2 main feature

- Standard DB25 connector, can be wire to IPG laser directly.
- Galvo control signal is digital, which can be connect to most scanhead directly.
- on-the-fly marking feature. A encoder can be used to surveillance the pipeline speed real-timely.
- Multiple boards on 1 computer: One computer can control up to 8 control board to mark different pattern simultaneously
- Extension axis(step motor or sever motor): two set of direction/pulse signal can be used to control 2 step(server) motors.
- 16 general input signals(TTL compatible): In0-In13, XORG0(IN14), YORG0(IN15).
- 8 general output signals(TTL compatible): Out0-7 coming out of Con5. Out0 - 3 are TTL outputs. Out4-7 can be configured as OC outputs or TTL outputs.
- LaserErr signal: this signal will be activated when there is an error occurs in the laser, OC output.
- Remark function: this function is used to remark what ever is in the memory of the board, especially convenient for high speed marking of a same pattern.
- Compatible with USB2.0 specifications.

1.3 Version illustration

In 2014 we update the board, on left top corner you will see the 'REV: 20141022', used to control D type laser, also can control B type laser. And also support YLPM type of laser.

REV \ LaserType	BType	DType	Comment
REV: 20070716-2	support	Not support	Old
REV: 20080425-3	support	support	USBLMC
REV: 20100511	support	support	2010 new
REV: 20101221	support	support	2010 new

2 electrical wiring

2.1 pin definition

2.1.1 power supply

The control board need a 5V DC power supply. We recommend a 5V/3A DC supply. The Vcc and Gnd pin are 4/5 and 12/13 of CON4 respectively. You may find in other connectors some Vcc/Gnd pins, but we strongly suggest you use the ones in CON4.

CON4 pins	Name	function
4, 5	VCC	+5V power supply.
12, 13	GND	Reference ground of the power supply.

2.1.2 CON1 : DB15 scanhead control

The signals that control scanhead are digital, therefore can be connected to the digital scanhead directly. Because the protocols that every manufacturer used are not always the same, you need to conform which protocol is used. We also provide a D/A converter in the package. The digital signal converted by which can be connected to a analog scanhead.

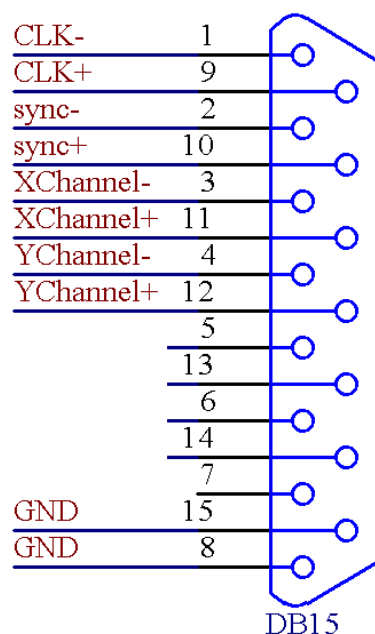

Fig 2-1 pin definition of CON1

Pin	Name	Function
1, 9	CLK- / CLK+	Clock signal- / Clock signal+
2, 10	SYNC- / SYNC+	Synchronization signal - / Synchronization signal+
3, 11	X Channel- / X Channel+	Scanhead signal X- / Scanhead signal X+
4, 12	Y Channel- / Y Channel+	Scanhead signal Y- / Scanhead signal Y+
5, 13	NULL	Reserved
6, 14,	NULL	Reserved
7	NULL	Reserved
8, 15	GND	Reference signal

To a commonly used two dimension scanhead, connecting CLK, SYNC, four wires for XChannel and Ychanne and the GND would be enough. We recommend a shielded twisted pair for all digital signal.

2.1.3 CON2 : DB25 Laser Control

CON2 socket can be connected to the DB25 connector through a pin to pin cable.

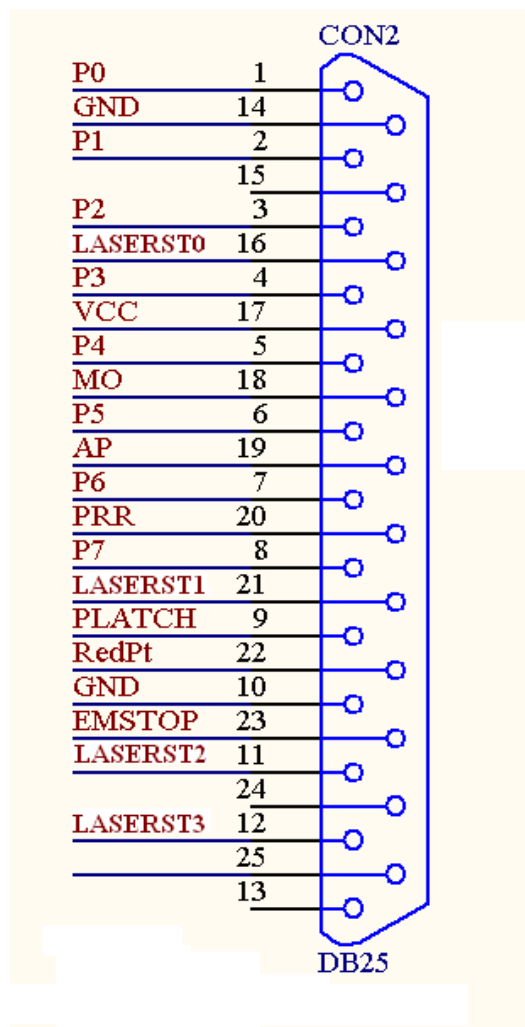

Pic2_2 Pin definition for CON2

Pin No.	Signal	Illustration
1—8	P0—P7	Laser power signal. TTL compatible
9	PLATCH	Power signal latch. TTL compatible.
10, 14,	GND	The reference ground of the control board.
16, 21, 11, 12	LASERST0~3	Alarm signal of Laser module
17	VCC	5V power output.
18	MO	Main oscillator signal. TTL compatible.
19	AP	Power amplifier signal. TTL compatible.

20	PRR	Pulse repetitive rate signal. TTL compatible.
22	RedPt	Red light pointer signal. TTL compatible.
23	EMSTOP	Emergency stop signal. TTL compatible.
13,24,25		Unconnected.

2.1.4 CON3 : DB9 On-the-fly interface

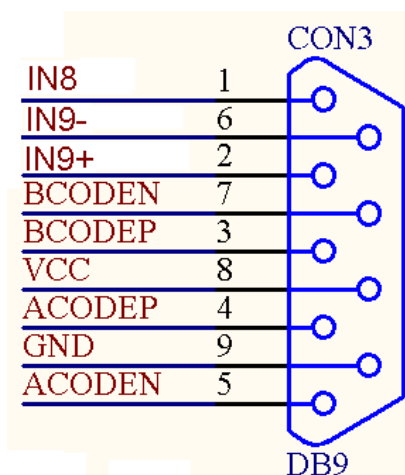

Pic 2-3 CON3 pin definition

Pin	Name	function	
1	IN8	Input port 8	Form a closed circuit with GND
2, 6	IN9+, IN9-	Input port 9	With a 1K resistor built in. if the input signal is over 12V, an external resistor is recommended.
3, 7	BCODEP/ BCODEN	Encoder input B+/B-	
4, 5	ACODEP/ACODEN	Encoder inputA +/A-	
8	VCC	+5V output	This is a power supply for external device. DO NOT CONNECT POWER SUPPLY HERE OR SHORT IT WITH GND. OTHERWISE IT WILL CAUSE DAMANGE OF THE BOARD.
9	GND	Reference ground	

2.1.5 CON4 : DB15 power supply and extension axis control.

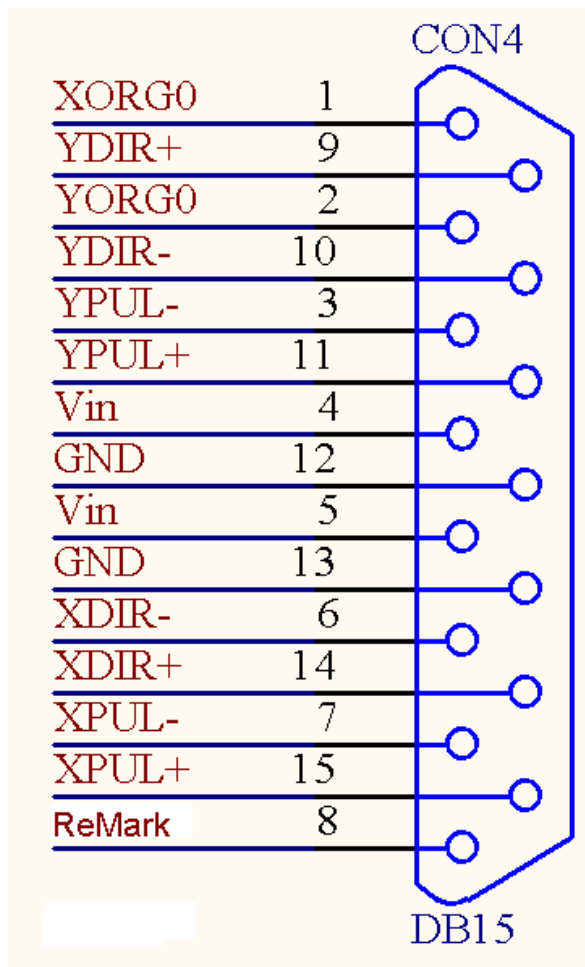

Fig 2-4 CON4 pin definition

Pin	NAME	Function
1	XORG0	The home signal of extension axis X. To use this pin just connect it and GND to a switch. In software In14 represents this pin.
2	YORG0	The home signal of extension axis X. To use this pin just connect it and GND to a switch. In software In14 represents this pin.
9, 10	YDIR+/YDIR-	Direction signal of extension axis Y (step motor or sever motor). It can be either a differential output or a TTL output(common anode).For common anode, use VCC and YDIR+ signals, and VCC is anode signal.
3, 11	YPUL-/YPUL+	Pulse signal of extension axis Y (step motor or sever motor). It can be either a differential output or a TTL output(common anode).For common anode, use VCC and YPUL+ signals, and

		VCC is anode signal.
4, 5	Vin	Input pin for 5V power supply.
12, 13	Gnd	Reference ground of 5V power supply
6, 14	XDIR-/XDIR+	Direction signal of extension axis Y (step motor or sever motor). It can be either a differential output or a TTL output(common anode).For common anode, use VCC and XDIR+ signals, and VCC is anode signal.
7, 15	XPUL-/XPUL+	Pulse signal of extension axis Y (step motor or sever motor). It can be either a differential output or a TTL output(common anode).For common anode, use VCC and XPUL+ signals, and VCC is anode signal.
8	ReMark	Repeat marking signal. Use GND as a reference ground, to use this signal just connect a switch between this pin and GND. When it is activated the control will mark the content in the cache.

2.1.6 CON5: DB25 digital IO

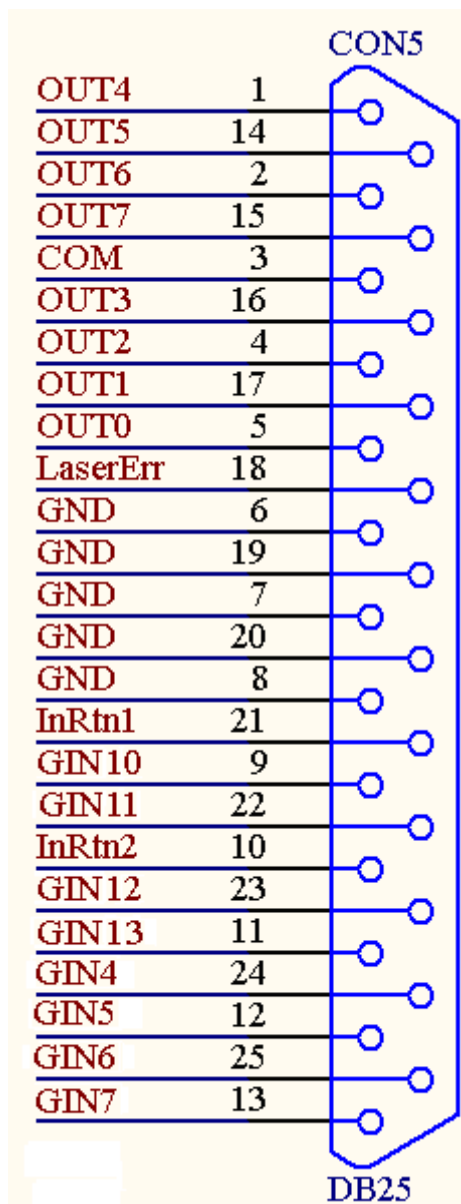

Fig 2-5 CON5 pin definition

pin	name	function
5, 17, 4, 16, 1, 14, 2, 15	Out0—7	General Output Out 0—Out 7, using GND as reference ground. They are all TTL output by default. Out 4-Out 7 can be configured to perform as a OC out put by jumper JP8-11.
3	COM	OC output, connect it to plus end of the pull power(for example 24V), in case of the output circuit will be wracked by inductiveload(for example: inductive relay)

18	Laser Err	OC output, if there is output, means laser has problem, then this signal will be pull to GND.
6, 7, 8, 19, 20	GND	Reference ground of control board.
21	INRTN1	Minus input of general input 10/11
9, 22	GIN10, GIN11	Plus input of general input 10/11, make up return circuit with INRTN1.
10	INRTN2	Minus input of general input 12/13
23, 11	GIN12, GIN13	Plus input of general input 12/13, make up return circuit with INRTN2.
24, 12, 25, 13	Gin4——7	General input in4-in7, using GND as a reference ground.

2.2 illustration on jumpers

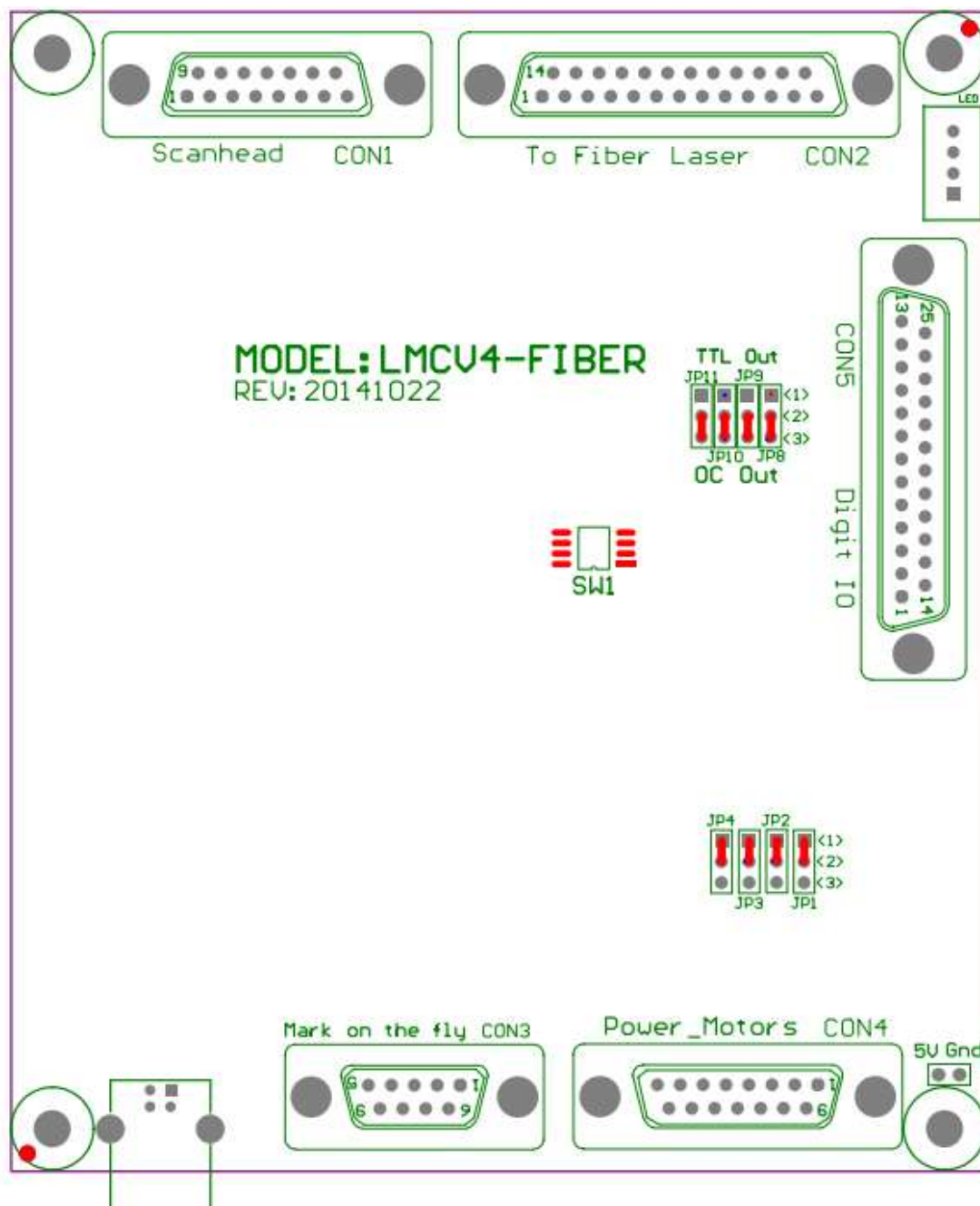

Fig 2-6 jumper illustration

pin	name	function
JP1, JP2 JP3, JP4	3	Direction/pulse signal setting of extend axes. JP1 and JP3 set direction signals; JP2 and JP4 set pulse signals. JP1 and JP2 correspond to extend axis Y; JP3 and JP 4 correspond to extend axis X. Short connecting JUMPER pin1&2 will make direction/pulse signals differential outputs. Respectively

		connect control card's DIR-, DIR+, PUL-, PUL+ to step driver's DIR-, DIR+, PUL-, PUL+; Short connecting JUMPER pin2-3 will make direction/pulse signals level outputs. In this case, respectively connect control card's VCC, DIR+, PUL+ to step driver's VCC, DIR, PUL。
JP5, JP6, JP7	2	Index numbers 0~7. Differentiate various cards when multi-cards are used at a time. JP8 -JP7- JP6 respectively correspond to binary b2 b1 b0. Short connecting JUMPER means 0, and not short connecting it means 1.
JP8, JP9, JP10, JP11	3	These jumper is used to setup the output mode for output 4-7. If those 1-2 pins are shorted then the output is at TTL mode, otherwise if 2-3 pins are connected it will be a OC output, these 4 pins represent OUT4,5,6,7 is the same descending order.

Default settings are:

JP1——JP4: 2-3 are shorted. The extension axis is signal is in a common anode mode.

JP5——JP7: Not connected.

JP8——JP11: 2-3 pin shorted OC output.

2.3 wiring for digital I/O.

2.3.1 I/O that can be connect to GND

As name suggested these kind of I/O can be connected to switch and then to the ground. In4-8,XORG0,YORG0, Remark are of these kind.

The following schematics are typical wiring for these kind of signal.

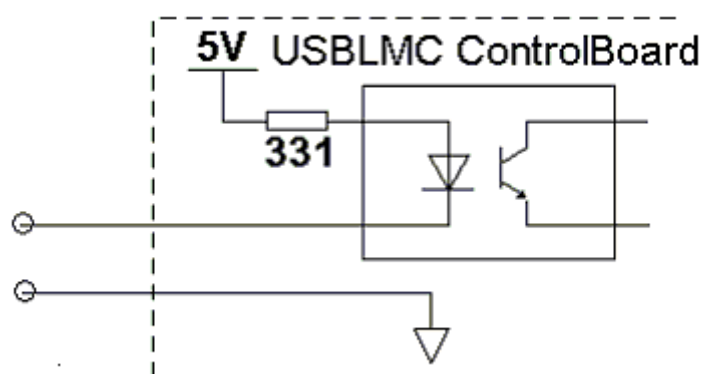

Pic 2-7 wiring for general input pins

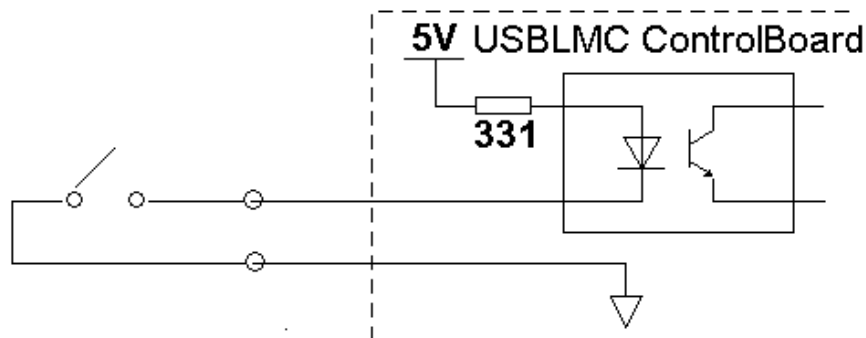

Pic 2-8 recommended wiring for general input pins

For these pins the resistor of the switch should be below 100ohm.

2.3.2 input signal In9-In13

The typical and recommend wiring of general input signals In9-In13 are shown in pic 2-9 and 2-10.

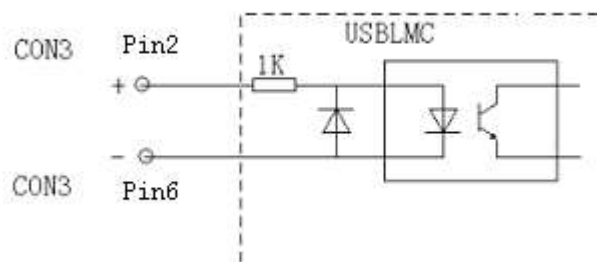

Pic 2-9 typical wiring for general

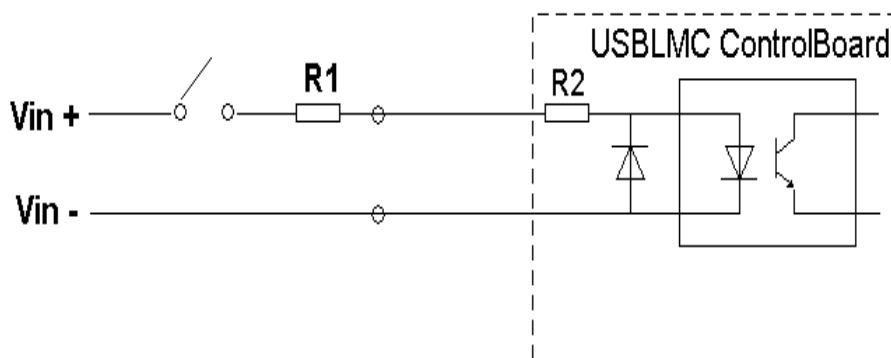

Pic 2-10 recommended wiring for general input pin in9

Whether to introduce R1 depends on the voltage. The goal here is to ensure that the input current is between 10mA and 15mA. If the voltage is over 12V, we recommend a current-limiting resistor. Assume that the current you choose is 12mA, then the resistor is calculated as follows:

$$R1 = \left(\frac{V_{in}}{12} - 1 \right) \times 1000 \quad \Omega$$

2.3.3 Out0—Out7

Out0/1/2/3 are TTL signal. Out4/5/6/7 can be configured as OC outputs or TTL outputs through jumper/

If a output is in TTL mode, The output must not be short circuited or wire to GND directly. Otherwiser the board can be damaged.

If a output is in OC mode, the typical wiring diagram is shown below, if you want to drive a inductive instrument, the COM signal(PIN3) must be wired to the anode of the power supply. The maximum driving current and voltage are 250mA and 40V respectively.

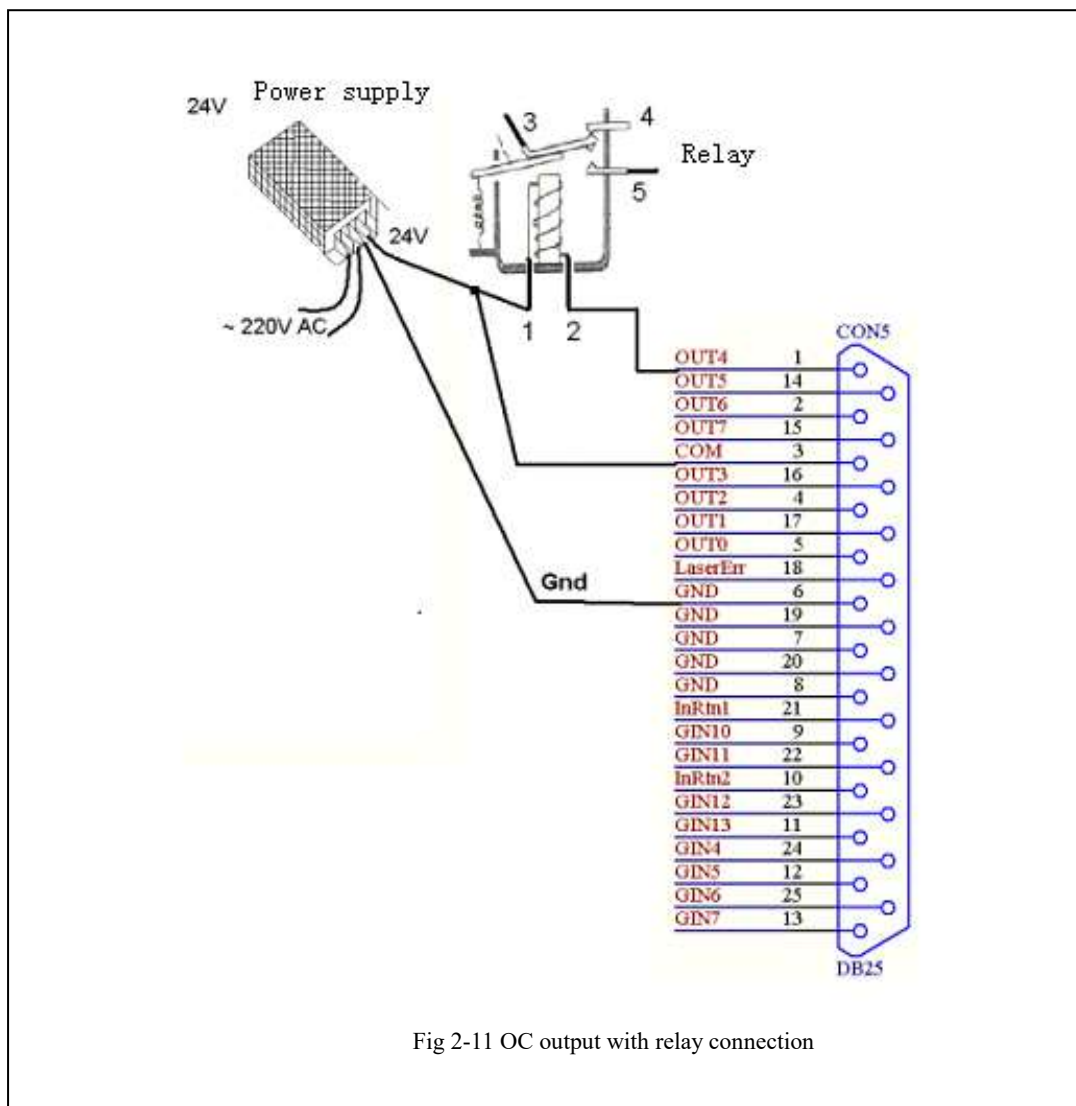

Fig 2-11 OC output with relay connection

2.3.4 Typical Connection of Digital Module

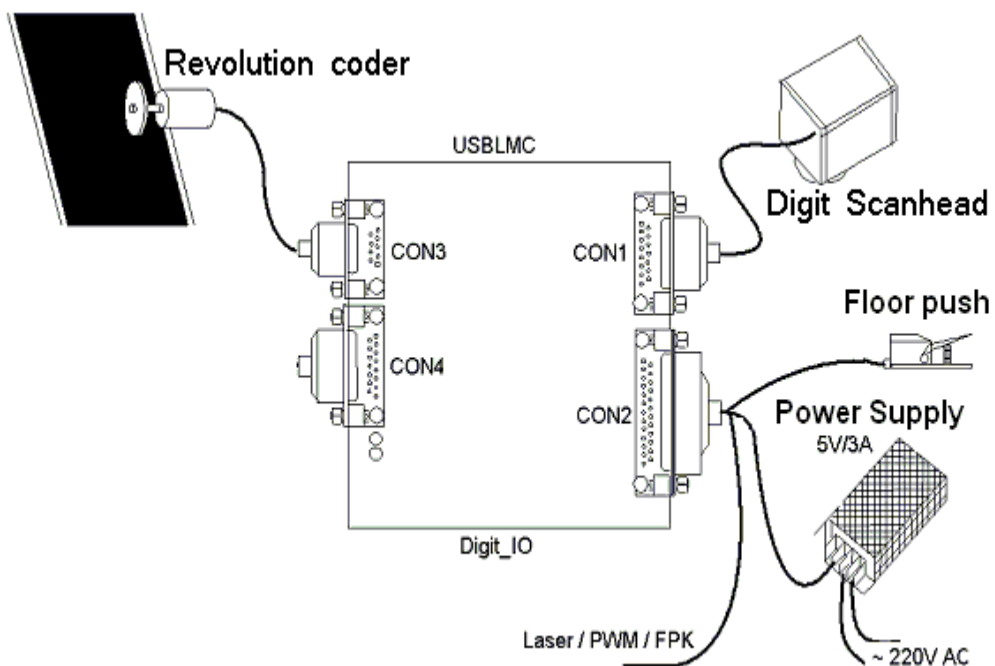

Fig. 1-15 Typical Connection of Digital Module

For the Floor push, it depends whether the rotary encoder needs connected. If the marking-on-fly function is not used, then there is no need to connect the rotary encoder.

2.5 Drawing of the board

